



PACKAGINGS: large size

ADAPTED TO THE PROFESSIONALS

Top down

Capacity (ml)
300ml

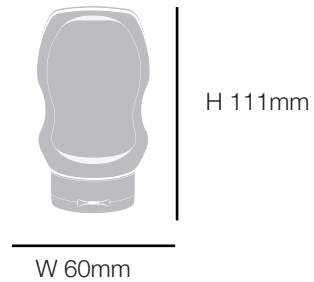

Squeezes bottles

Capacity (ml)
500 or 900ml

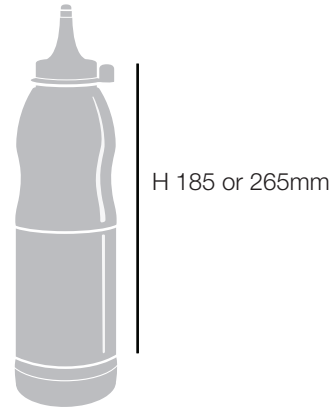

Tubs

Capacity (L)
From 1 to 10L

Diameter (mm)
From 133mm to 267mm

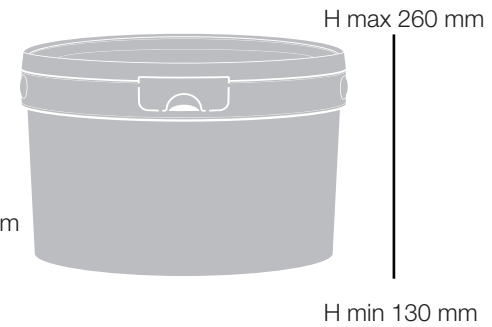

Flexible Bottles

Capacity (mL)
600ml

Heigh (mm)
220mm

Width (mm)
100mm

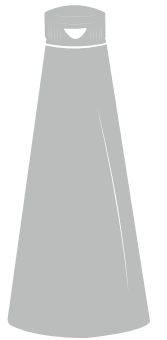

Doypack

Capacity (L)
1L

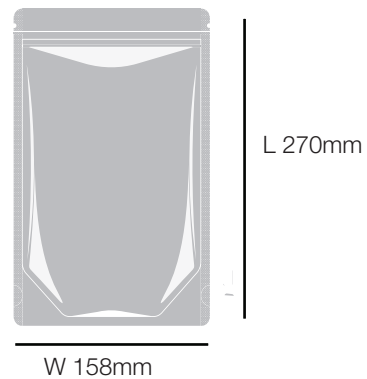

Jugs

Capacity (L)
From 5 to 25L

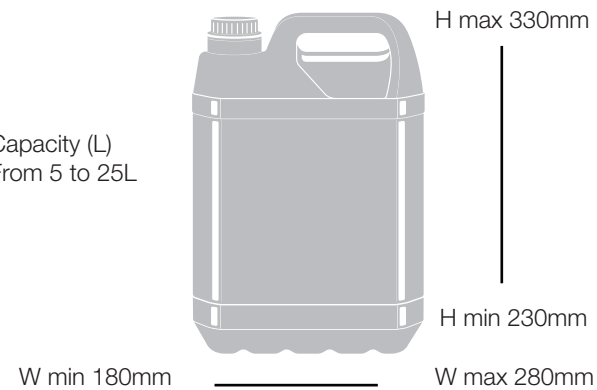

Pouches (Fitment from 3L)

Capacity (L)
From 0.5 to 6L

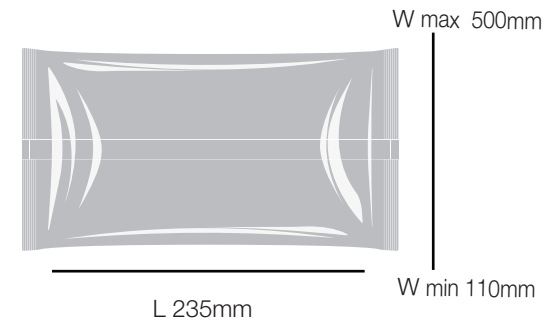

L : Lenght (mm)
W : Width (mm)
H : Height (mm)